

Ma

KEY STAGE

3

TIER

5–7**2003**

Mathematics test

Paper 2

Calculator allowed

Please read this page, but do not open your booklet until your teacher tells you to start. Write your name and the name of your school in the spaces below.

First name _____

Last name _____

School _____

Remember

- The test is 1 hour long.
- You may use a calculator for any question in this test.
- You will need: pen, pencil, rubber, ruler and a scientific or graphic calculator.
- Some formulae you might need are on page 2.
- This test starts with easier questions.
- Try to answer all the questions.
- Write all your answers and working on the test paper – do not use any rough paper. Marks may be awarded for working.
- Check your work carefully.
- Ask your teacher if you are not sure what to do.

For marker's
use only

Total marks	
Borderline check	

Instructions

Answers



This means write down your answer or show your working and write down your answer.

Calculators



You **may** use a calculator to answer any question in this test.

Formulae

You might need to use these formulae

Trapezium

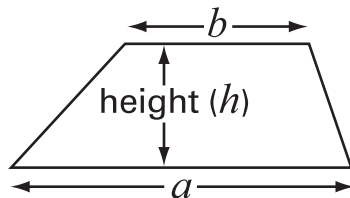

$$\text{Area} = \frac{1}{2}(a + b)h$$

Prism

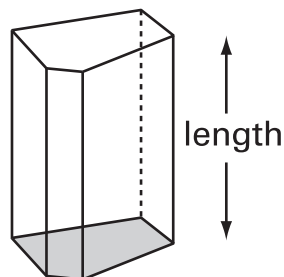

$$\text{Volume} = \text{area of cross-section} \times \text{length}$$

1. In this question, the grids are centimetre square grids.

(a) Draw a **rectangle** that has an **area of 12cm^2**

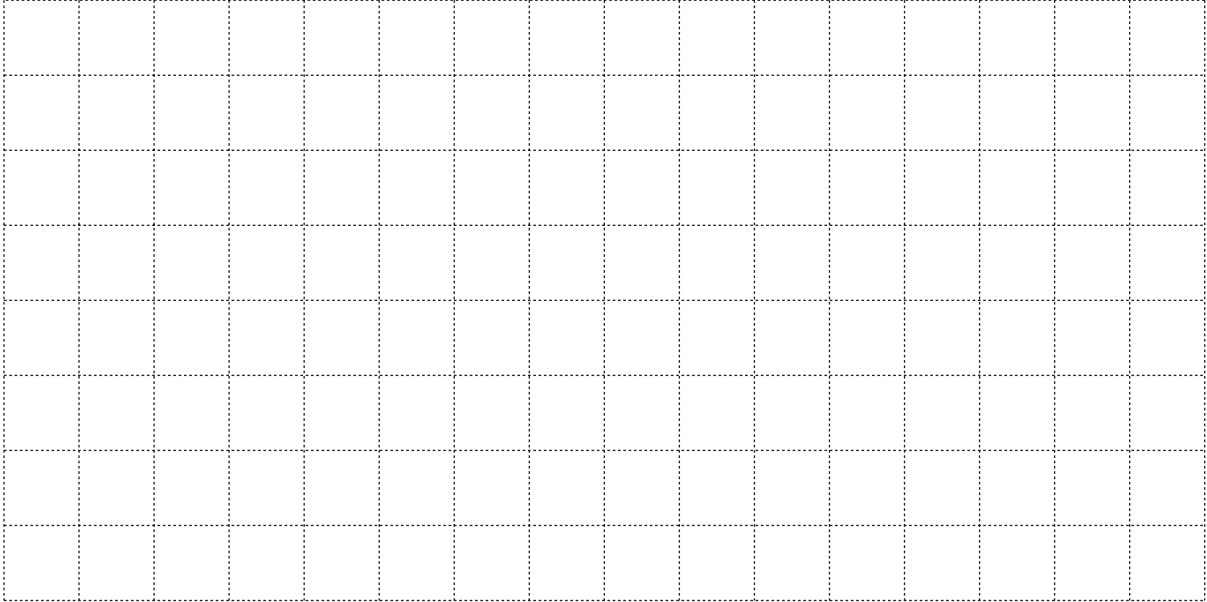

1 mark

(b) Draw a **triangle** that has an **area of 6cm^2**

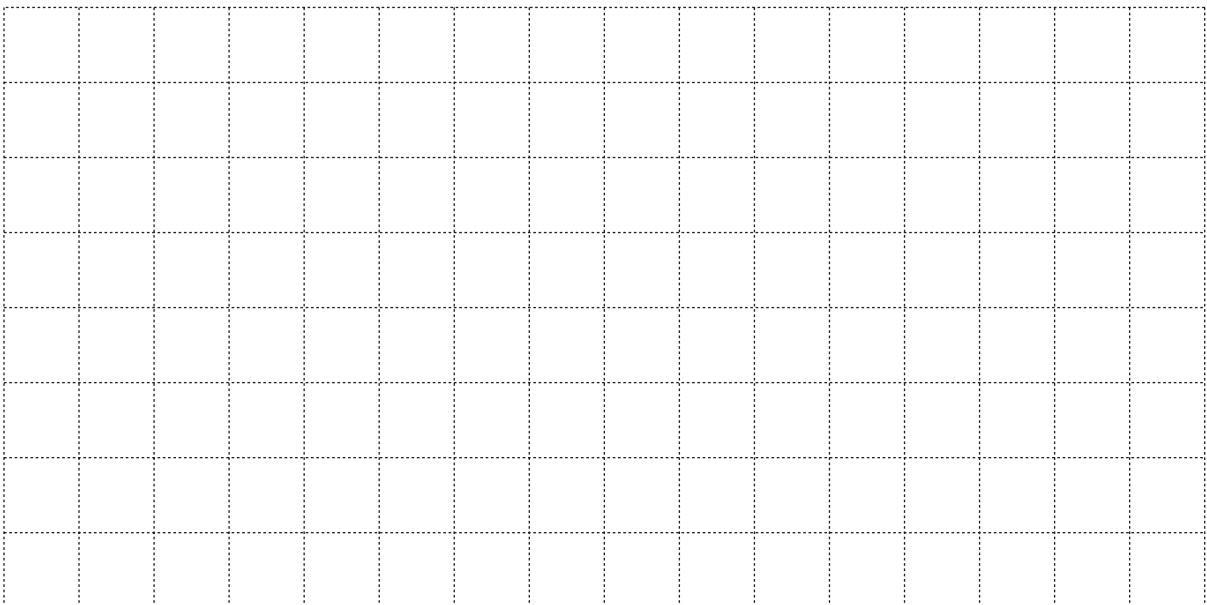

1 mark



2. (a) It is Tina's birthday. We do not know how old Tina is.

Call **Tina's age**, in years, n

The expressions below compare Tina's age to some other people's ages.

Use words to compare their ages. The first one is done for you.

Tina's age	n
Ann's age	$n + 3$

Ann is *3 years older than Tina*

Tina's age	n
Barry's age	$n - 1$



Barry is

Tina's age	n
Carol's age	$2n$



Carol is

.....
.....
2 marks

(b) In one year's time Tina's age will be $n + 1$

Write **simplified expressions** to show the ages of the other people in one year's time.

	Tina	Ann	Barry	Carol
Age now	n	$n + 3$	$n - 1$	$2n$
Age in one year's time	$n + 1$



.....
.....
2 marks

(c) When $n = 30$, find the value of $2n + 1$



.....

.....
1 mark

When $n = 30$, find the value of $2(n + 1)$



.....

.....
1 mark



3. Each diagram below was drawn on a square grid.

(a) Write what **percentage** of each diagram is shaded.

The first one is done for you.



..... 75 %



..... %

.....
1 mark



..... %

.....
1 mark

(b) Explain how you know that $12\frac{1}{2}\%$ of the diagram below is shaded.



.....
1 mark

(c) Shade $37\frac{1}{2}\%$ of the diagram below.



.....
1 mark

4. Some pupils plan a survey to find the most common types of tree in a wood.

Design 1

Instructions:

Write down the type of each tree that you see.

For example:

Elm, oak, oak, oak, sycamore, ash, ...

Design 2

Instructions:

Use these codes to record the type of each tree that you see.

Ash A
 Birch B
 Elm E
 Oak O
 Sycamore S

For example:

E, O, O, O, S, A, ...

Design 3

Instructions:

Use a tally chart to record the type of each tree that you see.

For example:

Type of tree	Tally
Ash	I
Birch	
Elm	I
Oak	III
Sycamore	I
Other	

The pupils will only use one design.

(a) Choose a design they should **not** use.



Design

Explain why it is not a good design to use.



.....
1 mark

(b) Choose the design that is the best.



Design

Explain why it is the best.



.....
1 mark



5. (a) Jo has these **4 coins**.



Jo is going to take one of these coins at random.

Each coin is equally likely to be the one she takes.

Show that the **probability** that it will be a **10p** coin is $\frac{1}{2}$



.....
1 mark

(b) Colin has **4 coins** that total **33p**.

He is going to take one of his coins at random.

What is the probability that it will be a **10p** coin?

You **must** show your working.



.....
1 mark

6. Look at the diagram.
 Triangle ABD is the reflection of triangle ABC in the line AB.

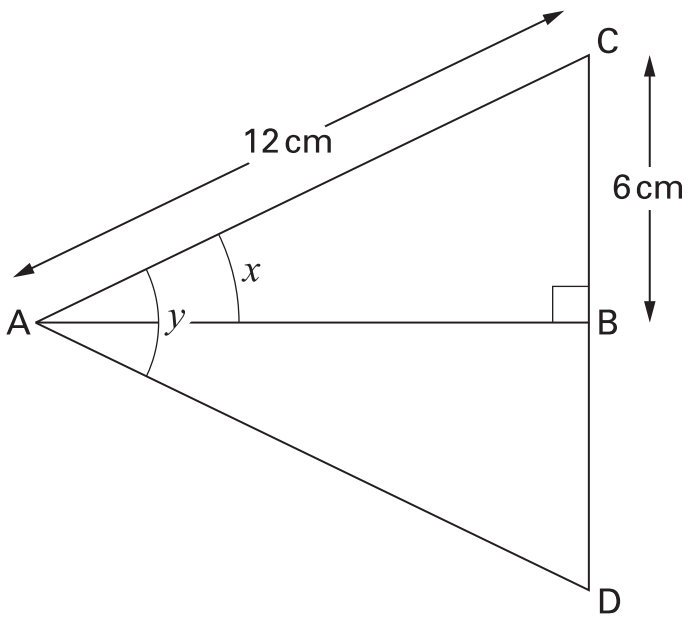

Not drawn accurately

Fill in the gaps below to explain how to find angle x

The length of AC is ¹² cm.



The length of AD is cm.

The length of CD is cm.

ACD is an equilateral triangle because 1 mark

so angle y is^o because 1 mark

so angle x is^o because 1 mark



7. (a) A glass holds **225 ml**.



225 ml

An adult needs about **1.8 litres** of water each day to stay healthy.

How many glasses is that?

Show your working.



.....

.....
.....
2 marks

(b) An adult weighs **80 kg**.

60% of his total mass is water.

What is the mass of this water?



..... kg

.....
1 mark

8. Paul is 14 years old.
His sister is exactly **6 years younger**, so this year she is 8 years old.

This year, the ratio of Paul's age to his sister's age is 14 : 8

14 : 8 written as simply as possible is **7 : 4**

- (a) When Paul is **21**, what will be the ratio of Paul's age to his sister's age?
Write the ratio as simply as possible.



..... :

.....
1 mark

- (b) When his sister is **36**, what will be the ratio of Paul's age to his sister's age?
Write the ratio as simply as possible.



..... :

.....
1 mark

- (c) Could the ratio of their ages ever be **7 : 7**?
Tick (✓) Yes or No.



Yes No

Explain how you know.



.....
1 mark



9. The information in the box describes three different squares, A, B and C.

The **area** of square A is **36cm^2**

The **side length** of square B is **36 cm**

The **perimeter** of square C is **36 cm**

Put squares A, B and C in order of size, starting with the smallest.

You **must** show calculations to explain how you work out your answer.



.....
smallest

.....

.....
largest

.....
.....
2 marks

10. The squared paper shows the nets of cuboid A and cuboid B.

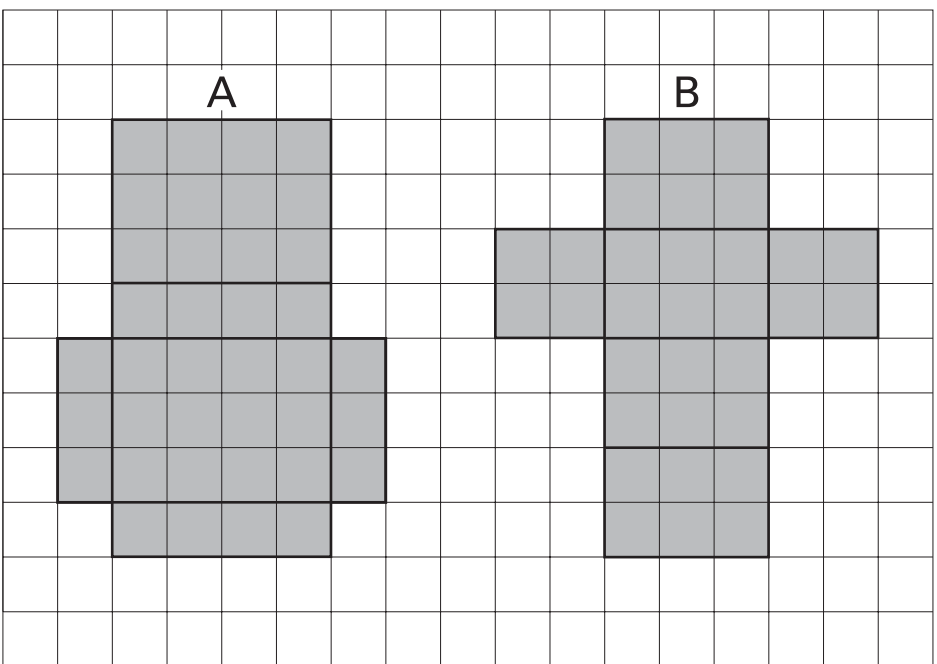

(a) Do the cuboids have the **same surface area**?
 Show calculations to explain how you know.



.....
 1 mark

(b) Do the cuboids have the **same volume**?
 Show calculations to explain how you know.



.....

 2 marks



11. Two beaches are very similar.

A survey compared the number of animals found in one square metre on each beach.

One beach had not been cleaned.

The other beach had been cleaned.

Beach: Not cleaned

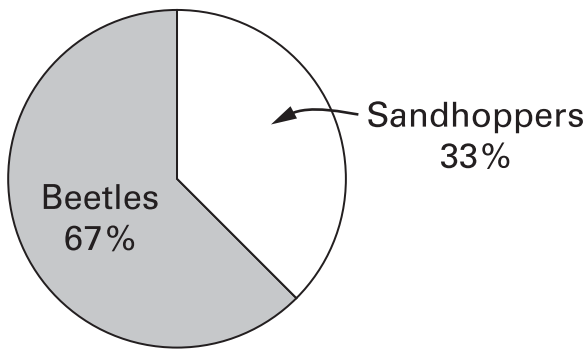

Beach: Cleaned

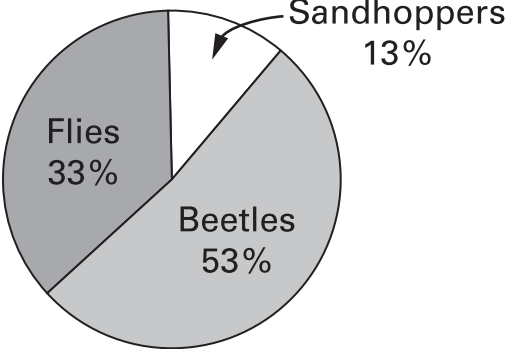

(a) The data for the beach that had **not been cleaned** represent **1620** animals. Complete the table to show how many of each animal were found.

Beach: Not cleaned	
	Number found
Sandhoppers	
Beetles	
Flies	

.....
.....
2 marks

(b) The data for the beach that had been **cleaned** represent **15** animals.

Complete the table to show how many of each animal were found on the cleaned beach.

Beach: Cleaned	
	Number found
Sandhoppers	
Beetles	
Flies	

.....
.....
2 marks

(c) Cleaning the beach changes the numbers of animals and the proportions of animals.

Write a sentence to describe **both** these changes.



.....
1 mark



12. Find the values of t and r

$$\frac{2}{3} = \frac{t}{6}$$



$t = \dots\dots\dots$

.....
1 mark

$$\frac{2}{3} = \frac{5}{r}$$



$r = \dots\dots\dots$

.....
1 mark

13. This pattern has rotation symmetry of order 6

(a) What is the size of angle w ?

Show your working.

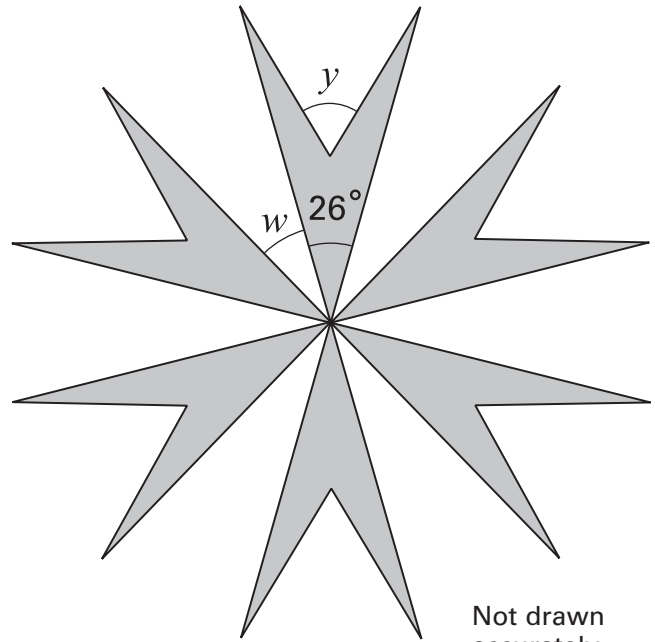

Not drawn accurately

.....
o

.....
.....
2 marks

(b) Each quadrilateral in the pattern is made from two congruent **isosceles** triangles.

What is the size of angle y ?

Show your working.

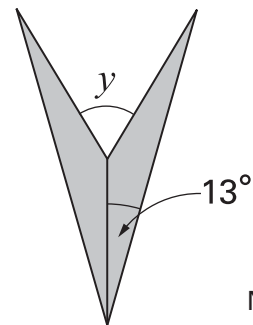

Not drawn accurately

.....
o

.....
.....
2 marks



14. On the square grids below you can join dots with two different length lines.
Length m is greater than length k

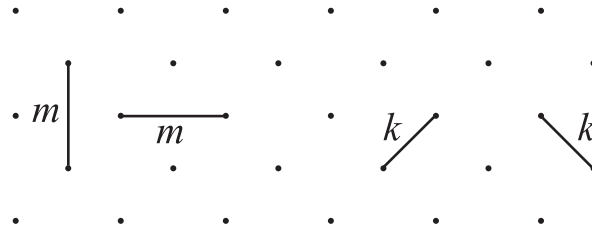

- (a) Draw a shape with each perimeter shown below.
The first one is done for you.

Perimeter $4k + 3m$

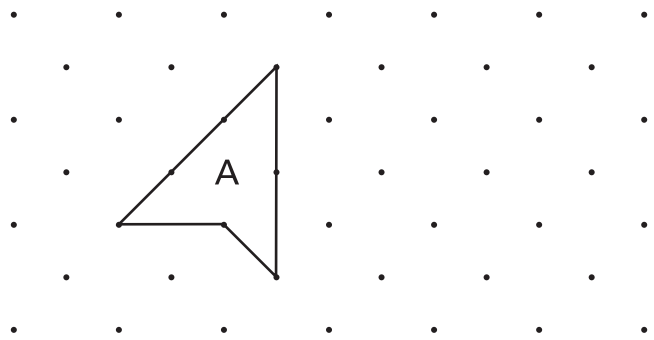

Perimeter $4k + m$

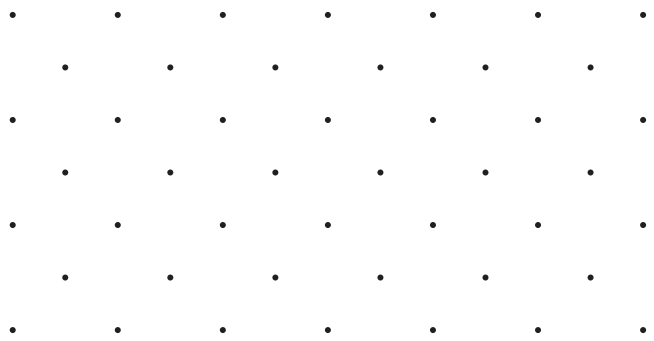

1 mark

Perimeter $2(2k + m)$

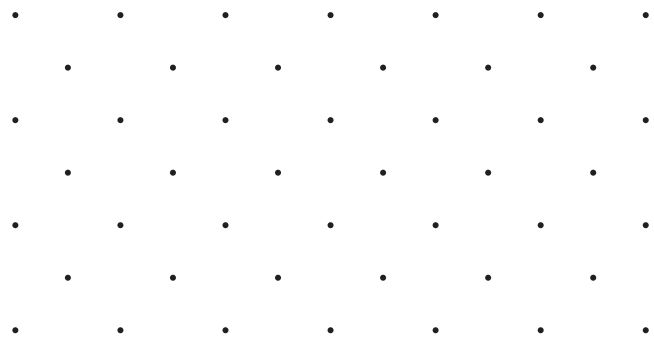

1 mark

(b) What is the **area** of this triangle?

Write it **in terms of m**

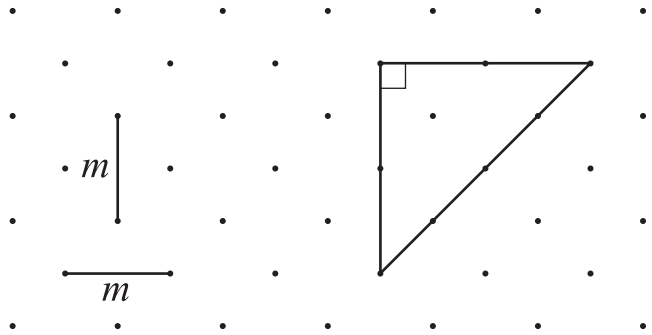

1 mark

(c) This is the **same triangle and grid**.

What is the area of the triangle?

Write it **in terms of k**

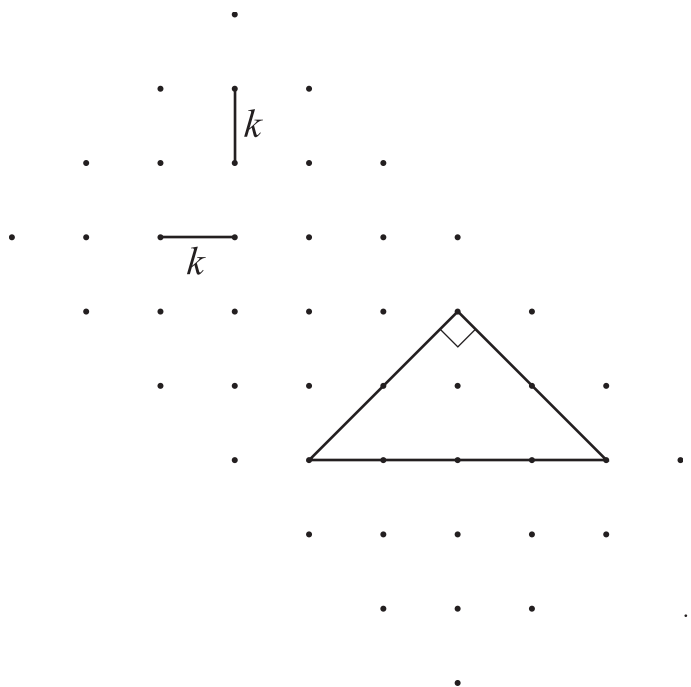

1 mark

(d) Using your answers to (b) and (c), explain why $m^2 = 2k^2$



1 mark



15. A book gives this information:

A baby giraffe was born that was 1.58 metres high.
It grew at a rate of 1.3 centimetres **every hour**.

Suppose the baby giraffe continued to grow at this rate.

About how many days old would it be when it was **6 metres** high?

Show your working.



..... days old

.....
.....
.....
3 marks

- 16.** Owls eat small mammals.
They regurgitate the bones and fur in balls called pellets.

The table shows the contents of **62** pellets from long-eared owls.

Number of mammals found in the pellet	1	2	3	4	5	6
Frequency	9	17	24	6	5	1

- (a) Show that the **total** number of mammals found is **170**



.....
1 mark

- (b) Calculate the **mean** number of mammals found in each pellet.
Show your working and give your answer correct to 1 decimal place.



.....

.....
.....
2 marks

- (c) There are about **10000** long-eared owls in Britain.
On average, a long-eared owl regurgitates **1.4 pellets** per day.

Altogether, how many **mammals** do the 10000 long-eared owls eat in **one day**?

Show your working and give your answer to the nearest thousand.



.....

.....
.....
2 marks



17. Here are four pictures, A, B, C and D. They are not to scale.

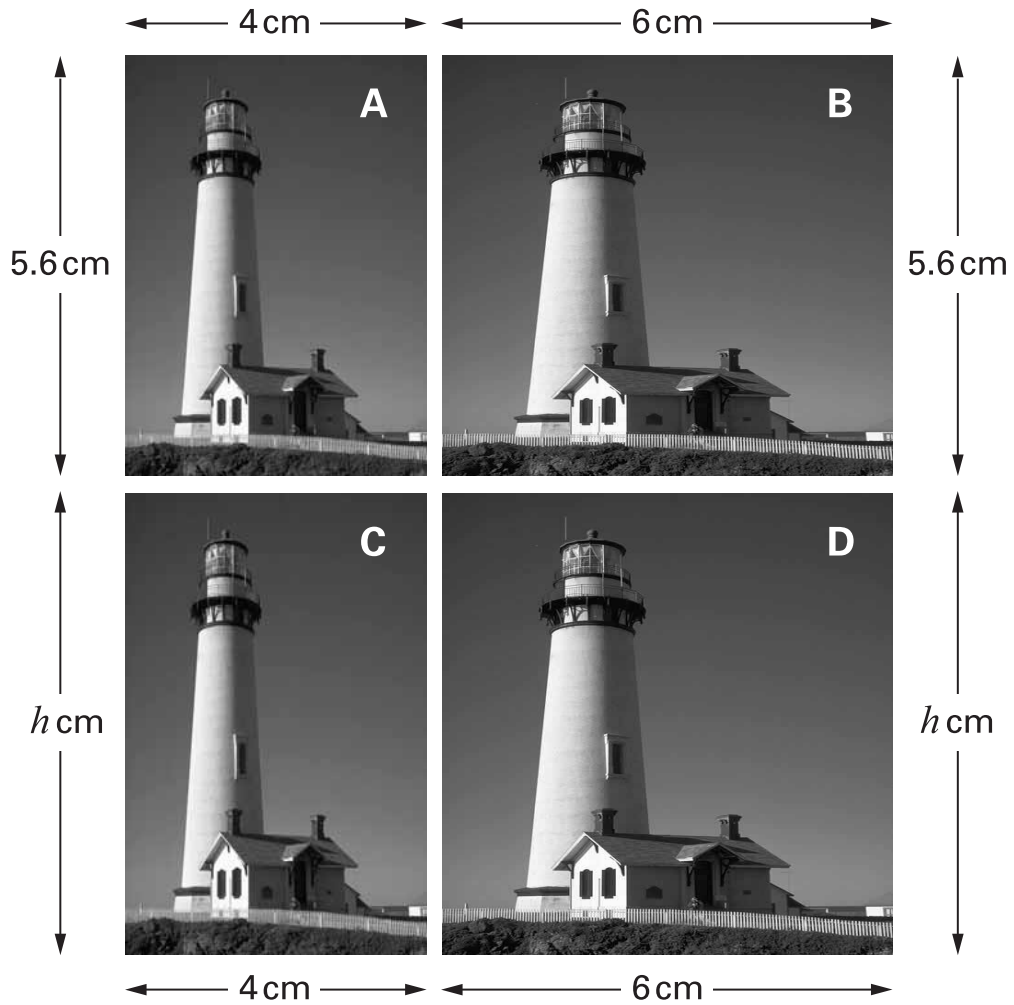

- (a) Picture A can be stretched horizontally to make picture B.
 Show that the horizontal factor of enlargement is **1.5**



.....
1 mark

- (b) Picture A can be stretched vertically to make picture C.
 The vertical factor of enlargement is **1.25**

What is the height, *h*, of picture C?



..... cm

.....
1 mark

18. A cup of coffee costs £ 1.75

The diagram shows how much money different people get when you buy a cup of coffee.

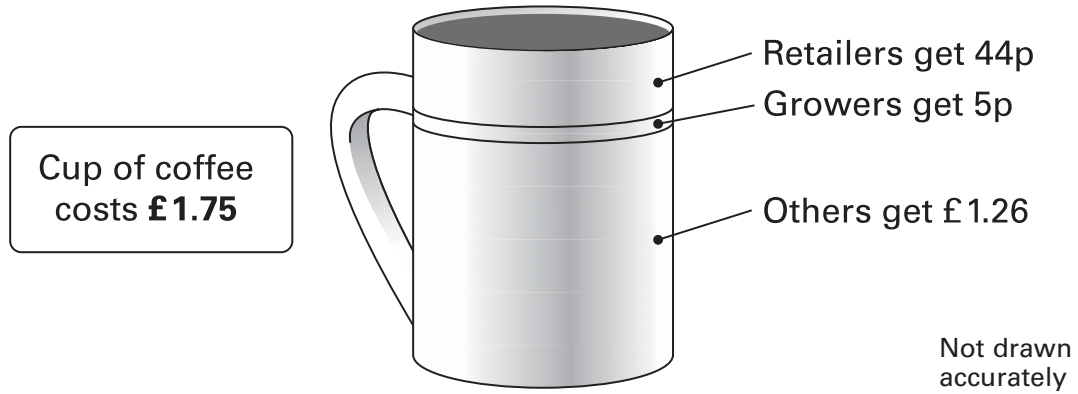

Complete the table to show what **percentage** of the cost of a cup of coffee goes to retailers, growers and others.

Show your working.



Retailers	%
Growers	%
Others	%

.....
.....
2 marks



19. The equation of the curve shown is

$$y = \pm \sqrt{\frac{x^3}{4-x}}$$

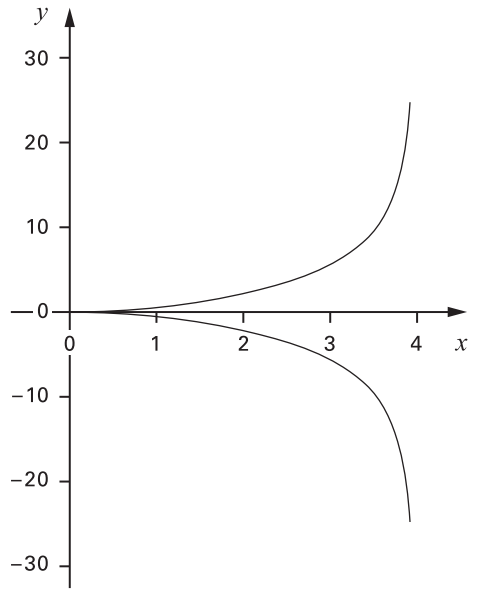

When $x = 2.5$ calculate the **positive** value of y
 Show all the digits on your calculator display.



.....

.....
1 mark

When $x = 2.5$ give **both** values of y correct to **3 significant figures**.



..... and

.....
2 marks