

Ma

YEAR
5

LEVELS
3-5

TEST
B

Mathematics

Test B

Calculator allowed



Name

Date

Total marks



Instructions

You **may** use a calculator to answer any questions in this test.

Work as quickly and as carefully as you can.

You have **45 minutes** for this test.

If you cannot do one of the questions, **go on to the next one.**

You can come back to it later, if you have time.

If you finish before the end, **go back and check your work.**

Follow the instructions for each question carefully.



This shows where you need to put the answer.

If you need to do working out, you can use any space on a page.

Some questions have an answer box like this:



For these questions you may get a mark for showing your method.

1

Write the missing numbers in this sequence.



64

32

16

4



1

2



A bag has **90** marbles in it.

4 children take **20 marbles each**.

How many marbles are left in the bag?



2

3

Jack leaves for school at this time.

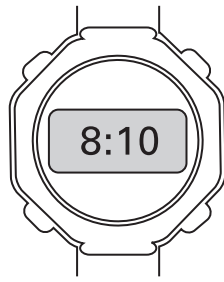

It takes him **40 minutes** to get to school.

Tick (✓) the time Jack gets to school.











4

Write what the missing numbers could be.



$$\square \times \square = 150$$

4

5

Write in the missing numbers.

One has been done for you.

rounded to the nearest
whole number is



6.01



6



9.51



7.75



5

6

Here are some **regular** 2-D shapes.

A hand hides part of each one.

Match each **regular** shape to its name.

One has been done for you.

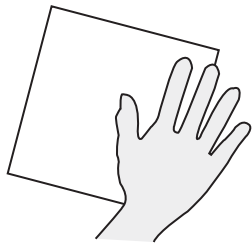

pentagon

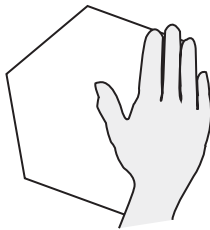

square

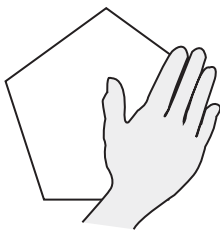

octagon

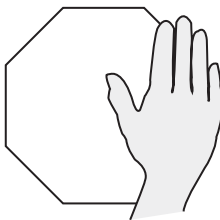

hexagon

7

Geeta has this spinner.

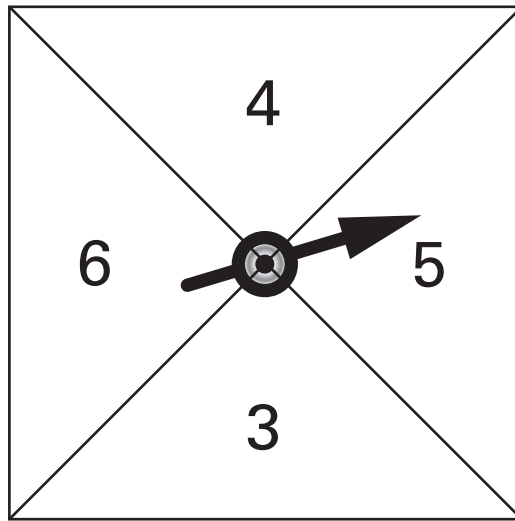

What is her chance of spinning the numbers in the boxes below?
Match each box to the correct word.

One has been done for you.

an odd number

certain



2

impossible

even chance

**a number
less than 10**

likely

8

Write in the missing number.



$$160 \div \boxed{} = 8$$

 8

9

Here is part of a number line.

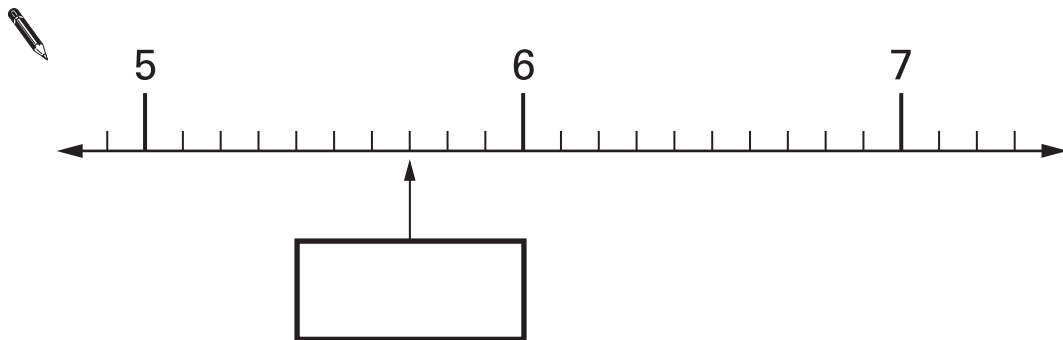
Write the **missing** number in the box.
 9

10

Kiz asked each child in his class,

'What kind of television programme do you prefer to watch?'

Here are his results.

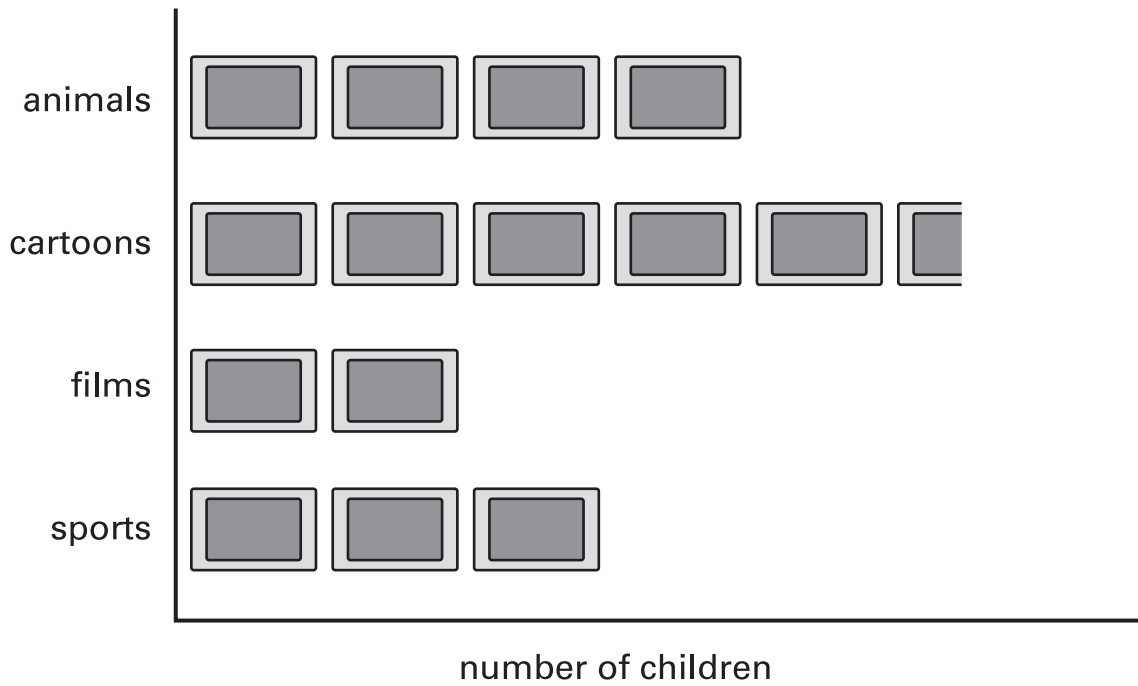

How many **more** children prefer to watch cartoons than films?

11

Emily is making a cake.

She puts flour on the scales.

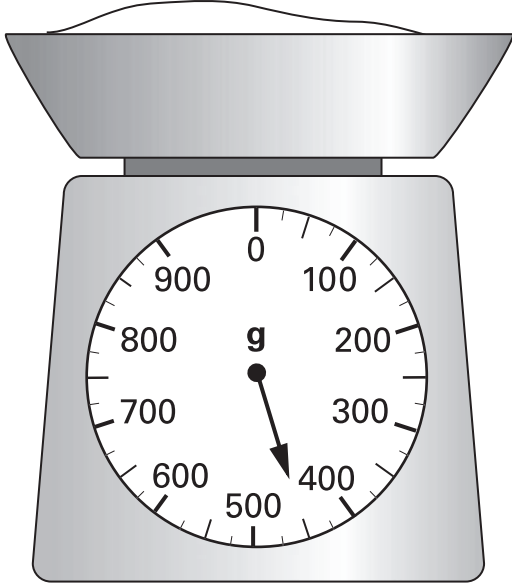

She then adds sugar to the flour.

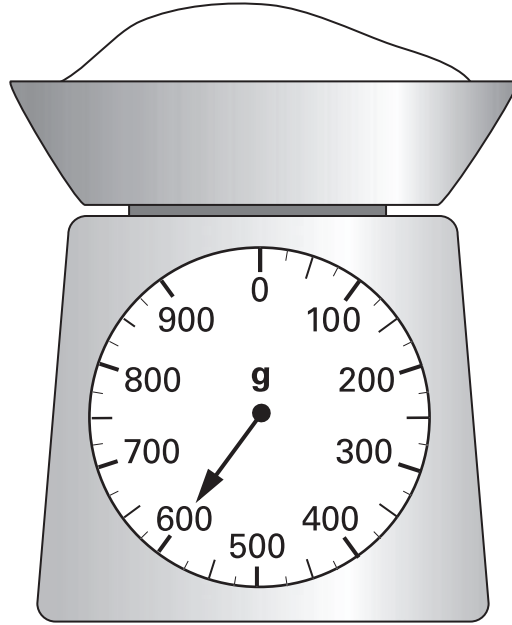

How much sugar does she add?

Show your **method**. You may get a mark.

g

11 i
11 ii



12

Write what the missing numbers could be.

$$120 = 100 + (\square - \square)$$

12

13

Draw the **reflection** of the shape in the **mirror line**.

Use a ruler.

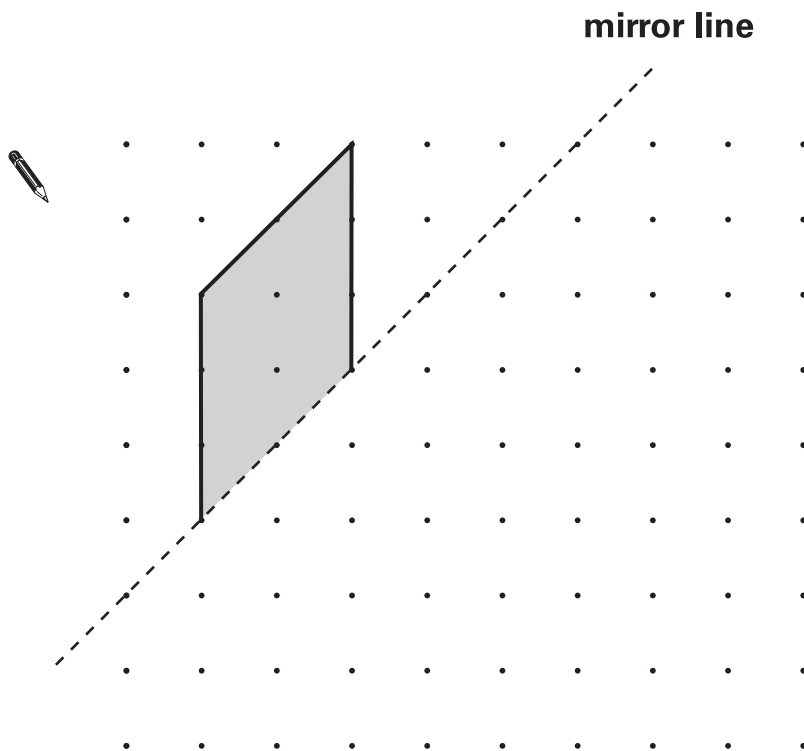

13

14

These graphs show data about Tom, Sam, Amy and Kiz.

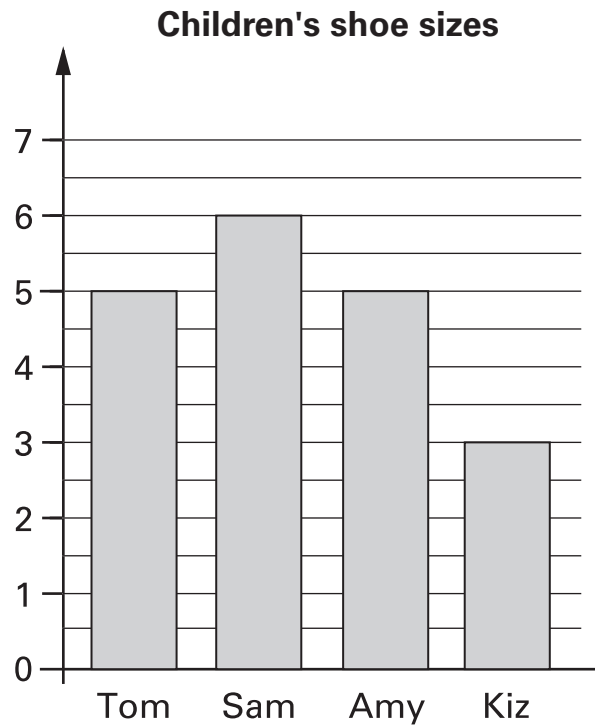
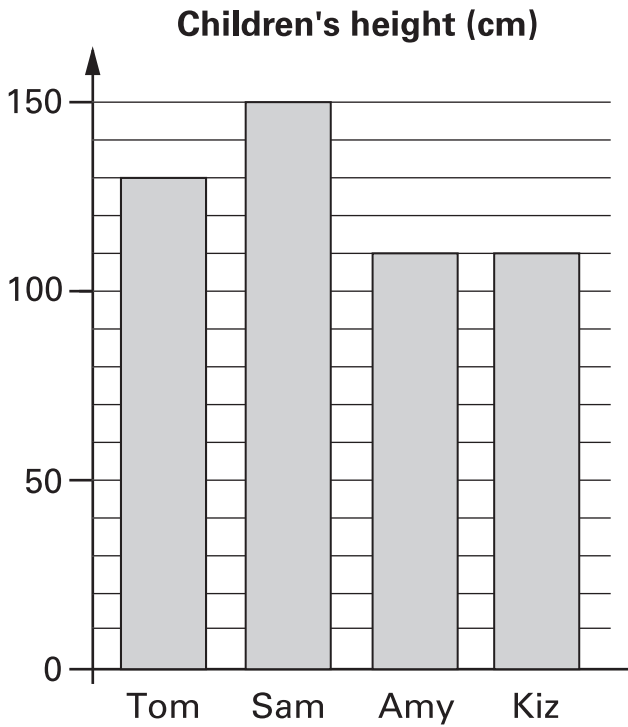

Use this data to write each child's name in the correct region on the Venn diagram.

One has been done for you.

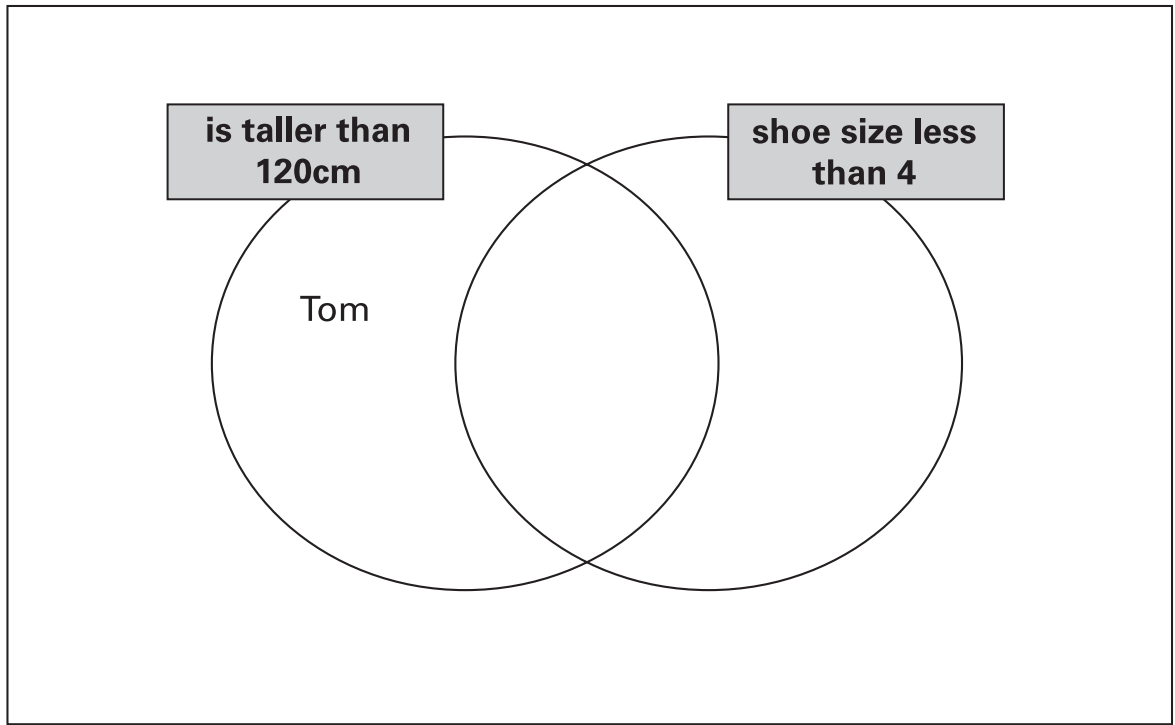

14i

14ii



15

Here are four digit cards.

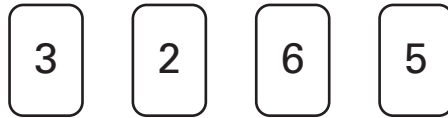
Write in **three** of the digits to make the **total nearest to 1000**

 $650 + \boxed{} =$

15

16A car costs **more** than **£8600** but **less** than **£9100**

Tick (✓) the prices that the car could cost.

- 
- £8569
 - £9090
 - £9130
 - £8999

16

17

Two children take part in a sponsored silence.

Sponsored Silence

Keep quiet!
Make money
for the hospital.



'I kept quiet from 10:30 to 10:35 in the morning. I got £3.42 a minute.'



Laura



Carl

'I kept quiet for half an hour. I got 35p a minute.'

How much money did each child get?



Laura

£

17a

Carl

£

17b

18

Match each quadrilateral to the correct description.

One has been done for you.

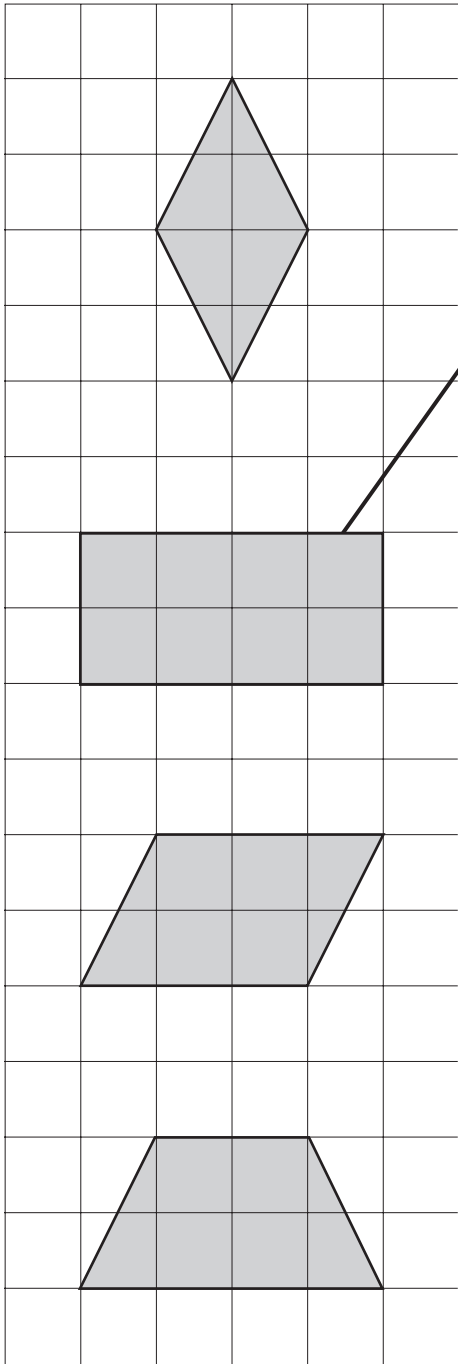

2 pairs of sides equal in length.
4 right angles.

Only 1 pair of parallel sides.

Opposite sides are parallel.
It has no lines of symmetry.

4 sides of equal length.
Opposite angles are equal.

19

Here is part of a number square.

The shaded numbers are part of a sequence.

	113	114	115	116
	123	124	125	126
	133	134	135	136
	143	144	145	146

Explain the rule for the sequence.



.....

.....

.....

20

Kyle has drawn triangle **ABC** on this grid.

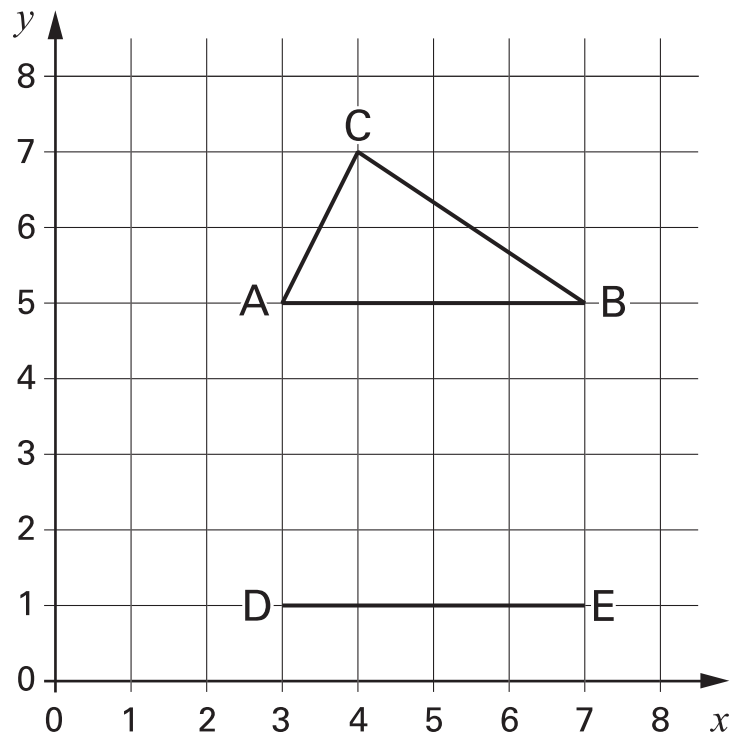

Holly has started to draw an **identical** triangle **DEF**.

What will be the coordinates of point **F**?



21

Sunshine Coach Company

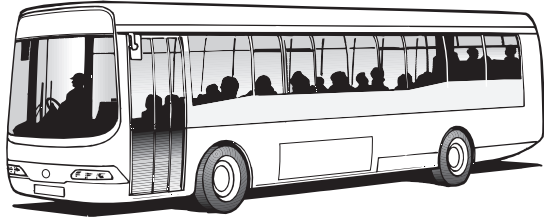

42-seat coaches

272 children and 26 adults from Hill School go on a coach trip.

How many **42-seat** coaches does the school need to hire?



Show your **method**.
You may get a mark.

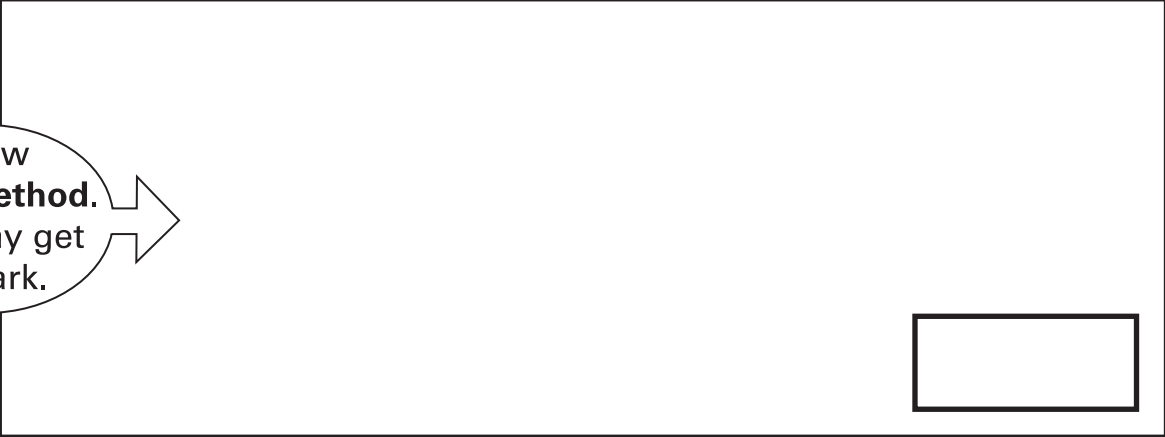

21i

21ii



22

Circle one amount each time to make these sentences correct.

One has been done for you.

The distance from
London to Manchester is about

320 cm
320 m
320 km



A tea cup is likely to hold about

15 ml
150 ml
1500 ml

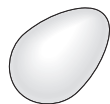

A hen's egg is likely to weigh about

6 g
60 g
600 g

23

Jordan, Anna and Ryan collect picture cards.

Cards are worth either **50** points or **100** points.

The table shows the cards they have.

Complete the table for Anna and Ryan.

	50 points	100 points	total number of points
Jordan	5 cards	2 cards	450 points
Anna	3 cards	<input type="text"/> cards	550 points
Ryan	4 cards	6 cards	<input type="text"/> points



24

The three numbers on **each line** add up to **763**

Write in the missing numbers.

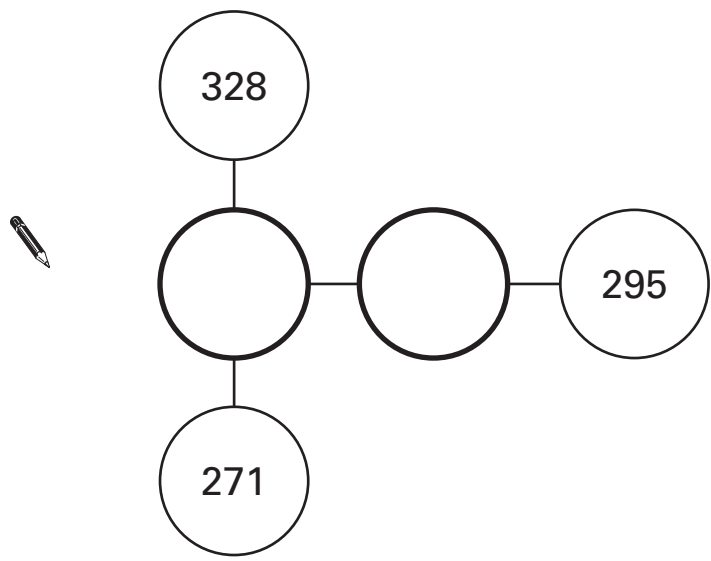

25

Calculate $\frac{1}{5}$ of 325

25

26

PQ is a straight line.

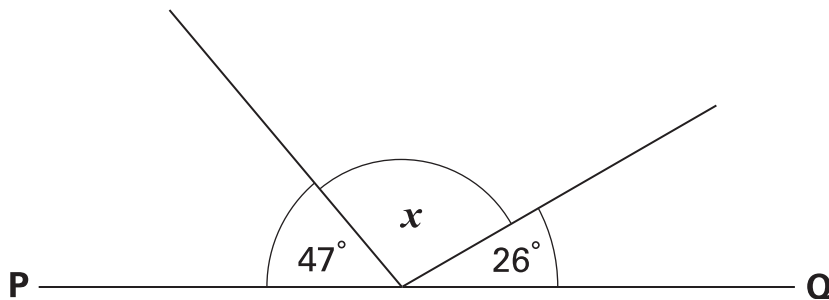
Not drawn
accuratelyCalculate the size of angle x .Do **not** use a protractor (angle measurer).

26

27Circle the **two** fractions that are equivalent to **0.6**

$\frac{6}{10}$

$\frac{1}{60}$

$\frac{60}{100}$

$\frac{1}{6}$

27

28Rectangle **ABCD** has a perimeter of **24 centimetres**.Sides **AB** and **DC** are **twice as long** as sides **AD** and **BC**.**Not actual size**Calculate the length of side **AD**.Do **not** use a ruler.

28

29

Write in the missing number.



$$\boxed{17.5} \times \boxed{6} = \boxed{25} \times \boxed{}$$

29

30

Here is a shaded square.

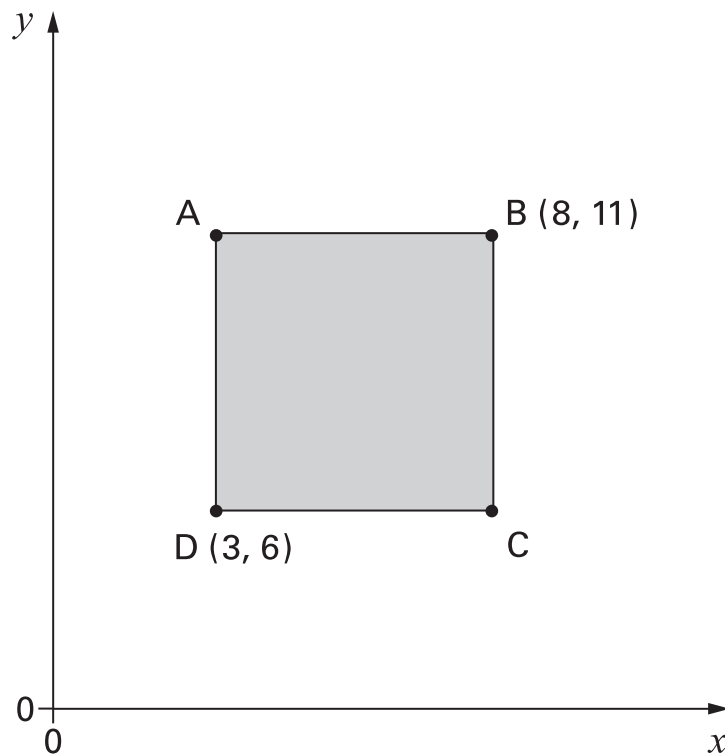

Write the coordinates for point A.



$$A = \boxed{(,)}$$

30

31

Here is a recipe for pasta sauce.

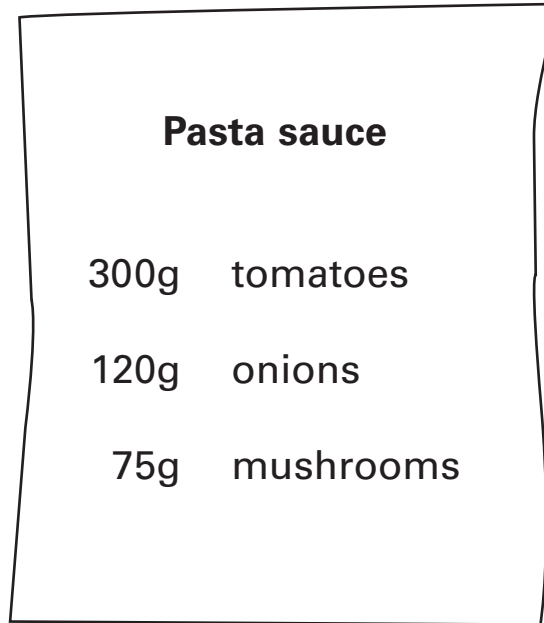

Josh makes the pasta sauce using **900g** of **tomatoes**.

What weight of **onions** should he use?

g

31

End of test

Blank page

